

Introduction

When it comes to fisheries issues, both public and private sectors have a responsibility and interests in managing it effectively.

Fisheries research is underlain by the principle of holistic planning and strategy making.

Two innovative methods are given by this study. First is the numerically simulate that the effect of opening ratio on the flow field to artificial reefs through the establishment of VOF model. Second is the interaction between the surface warming as well as hiatus to the CPUE and sample values of yellow fin tuna during 1994 to 2012, east pacific ocean. The density of yellow fin tuna showed a evidently reduction as well as a fragmentation, and this study also indicated population tendency may be involved ENSO events.

1. The Introduction to the Eddy Effect

The circulation near the sea or the island is often a good fishing ground. The Rossby wave brought different parameters of current water to coastal water.

Calculation of circulating flow rate :

$$u = \frac{1}{n} h^{\frac{2}{3}} \left[\frac{\Delta h}{l} \right]^{\frac{1}{2}}$$

Current generates a small scale circulation around the man-made objects.

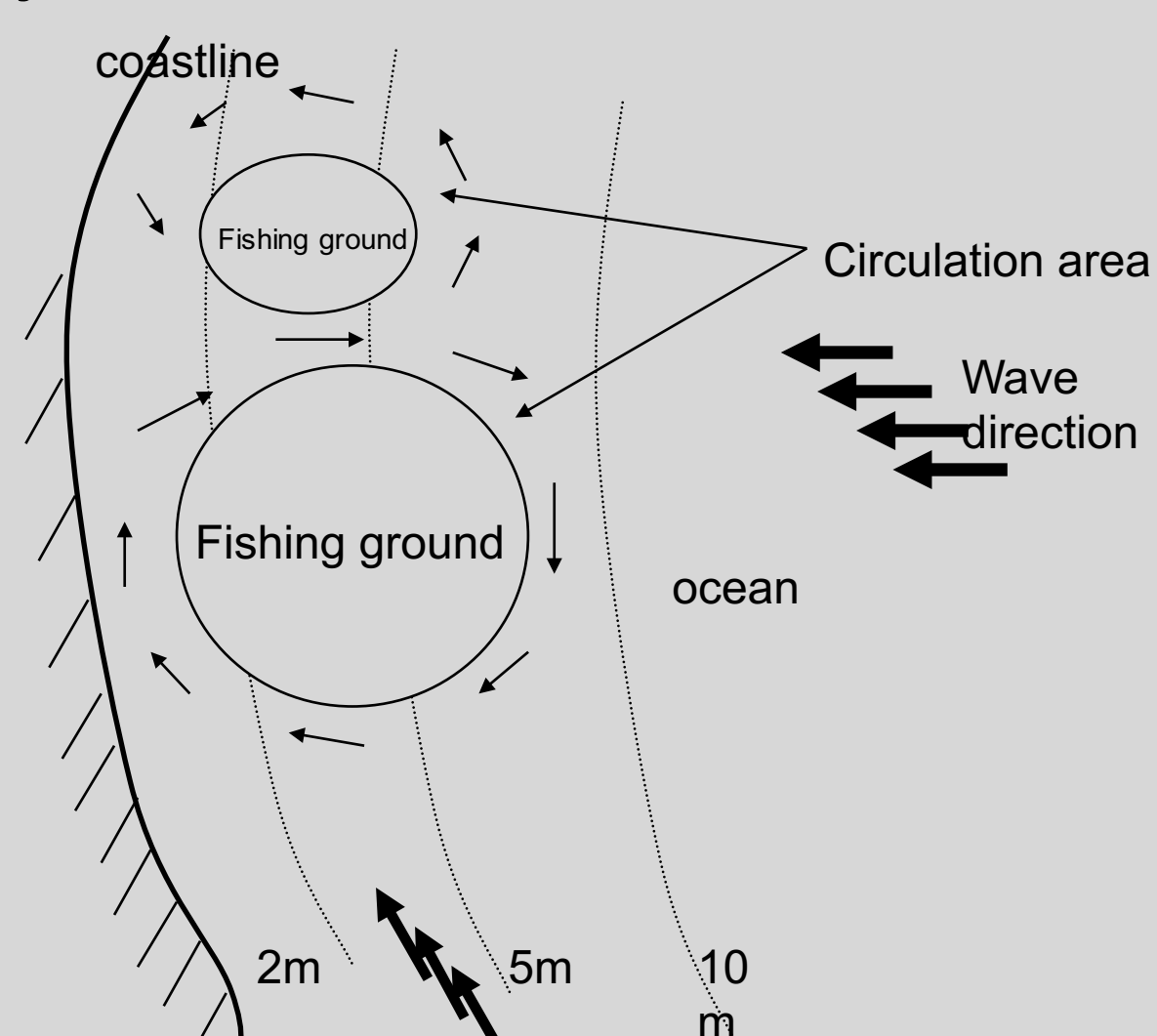

Figure 1: The mechanism of flow field effecting the fishing ground



Figure 2: The artificial reefs which we used to establish the numerical model

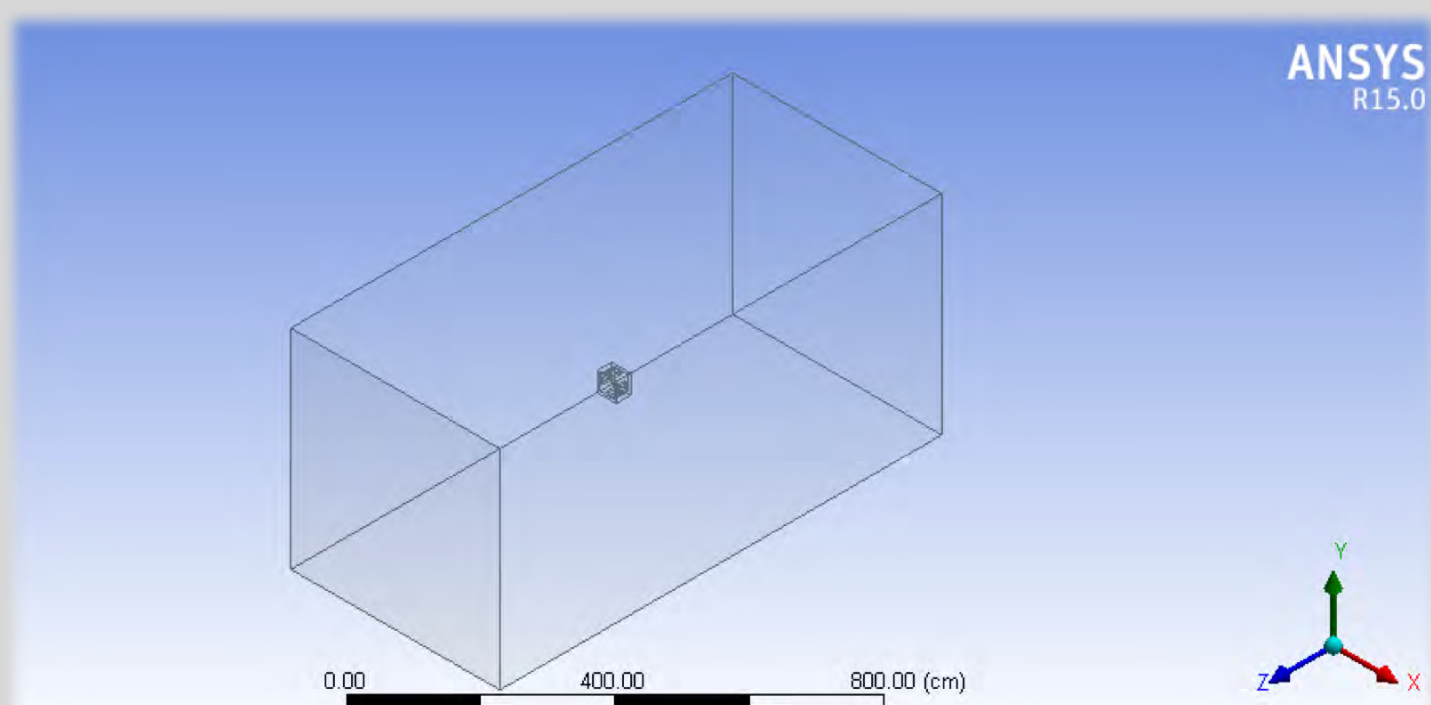

Figure 3: Using ANSYS to establish a 3D model

Do a numerical calculation by simulating the actual experiment flume. The size of calculation area set according to the circumstance of flume experiment. The area of calculation is 160 cm in length, 45 cm, the width of the tank, in width. The height of the area set to 60 cm in sink's height, 40 cm in sink's depth.

The Influence of Boundary Currents on Marine Ranching

Select RING k - epsilon turbulence model, call up the physical parameters of water, and mainly set the air phase, water for the second phase.

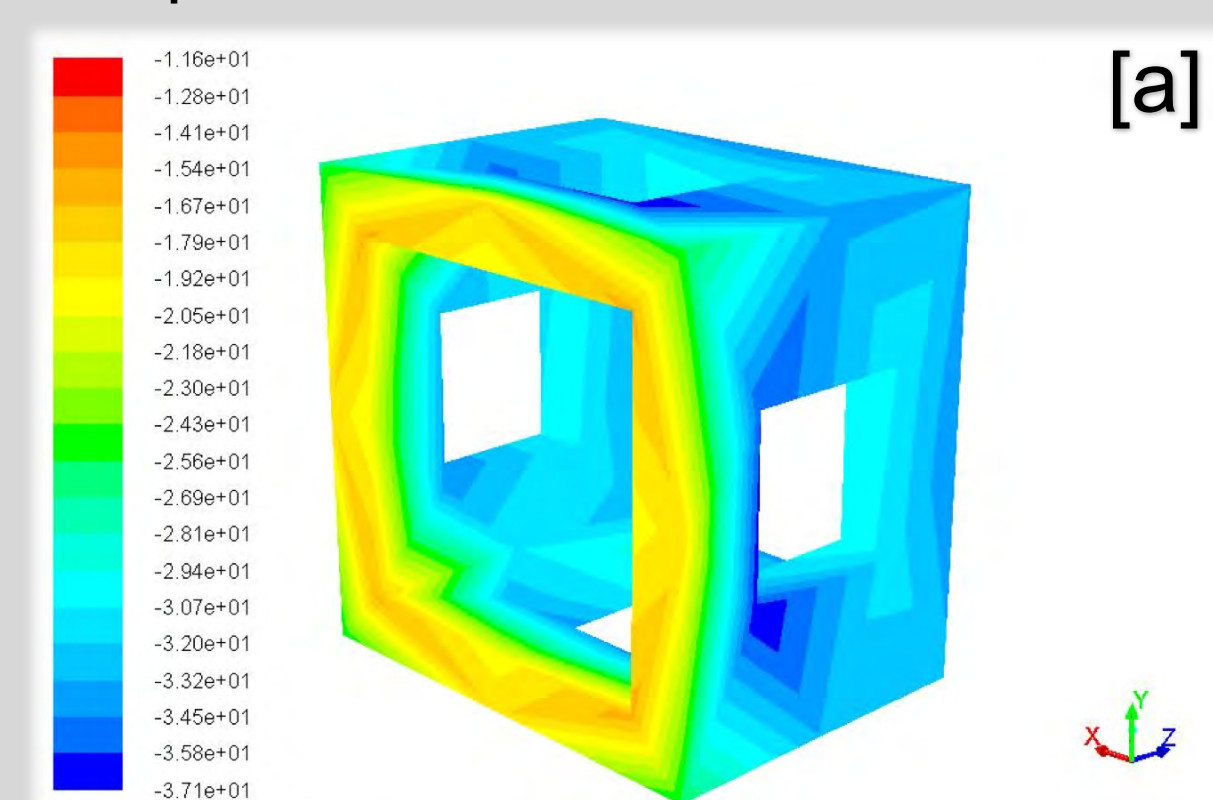

Figure 4: [a] Stress distribution of three dimensional model; [b] Horizontal velocity distribution

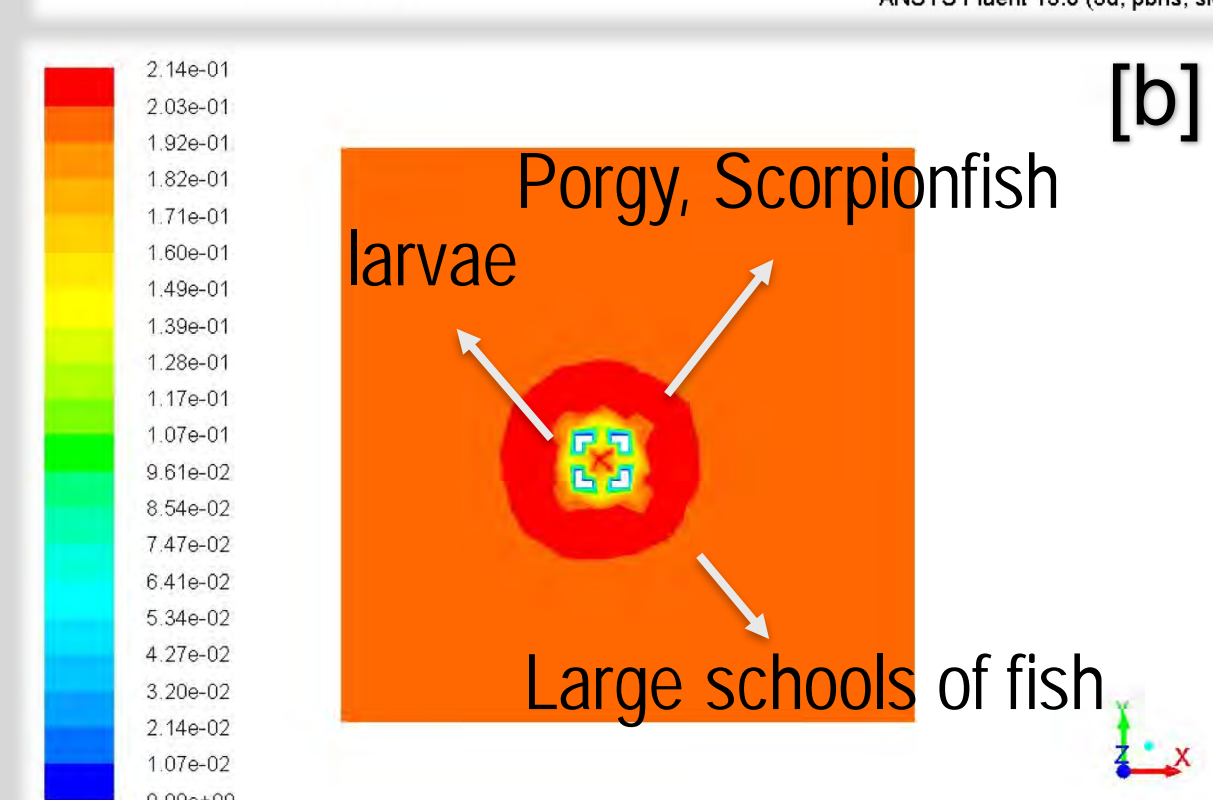

Figure 4: [a] Stress distribution of three dimensional model; [b] Horizontal velocity distribution

Analyze and discuss the results of numerical simulation

The experiment selected cubes of artificial reefs which sized 10 cm × 10 cm × 10 cm to put in the simulative sink which sized 160 cm (length) × 45 cm (width) × 60 cm (high). The flow velocity is 18 cm/s. The center of reefs opens. There are six kinds of circumstances, each opening ratio is r = 0, r = 0.1, r = 0.2, r = 0.3, r = 0.4, r = 0.5. The opening ratio is the ratio of opening size and reefs' length Through the process of the opening increasing from 0 to 0.6 , the Upwelling maximum speed decreases.

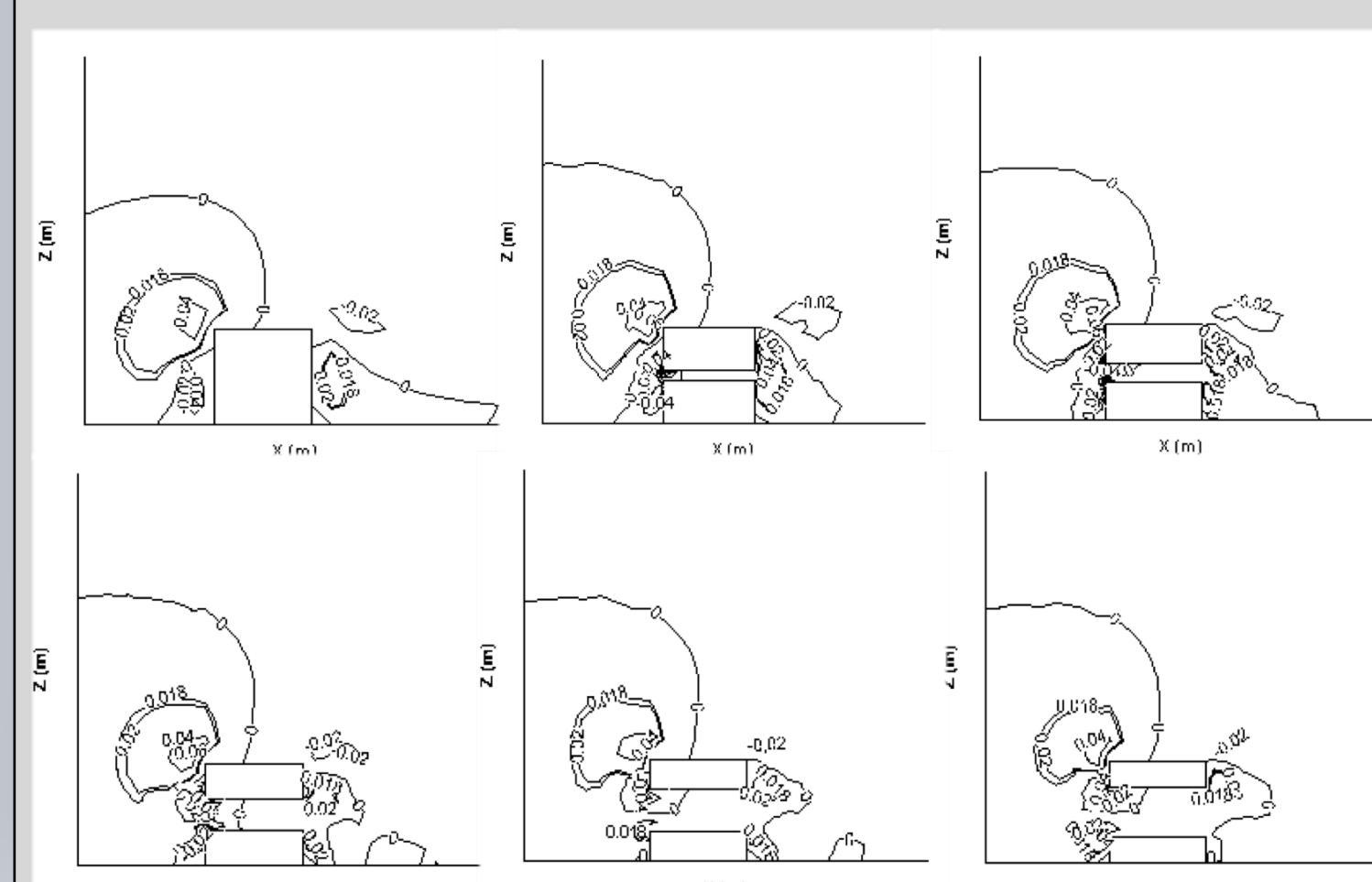

Figure 5: The distribution of upward and back eddy in the case of different opening size

Graphics / Images

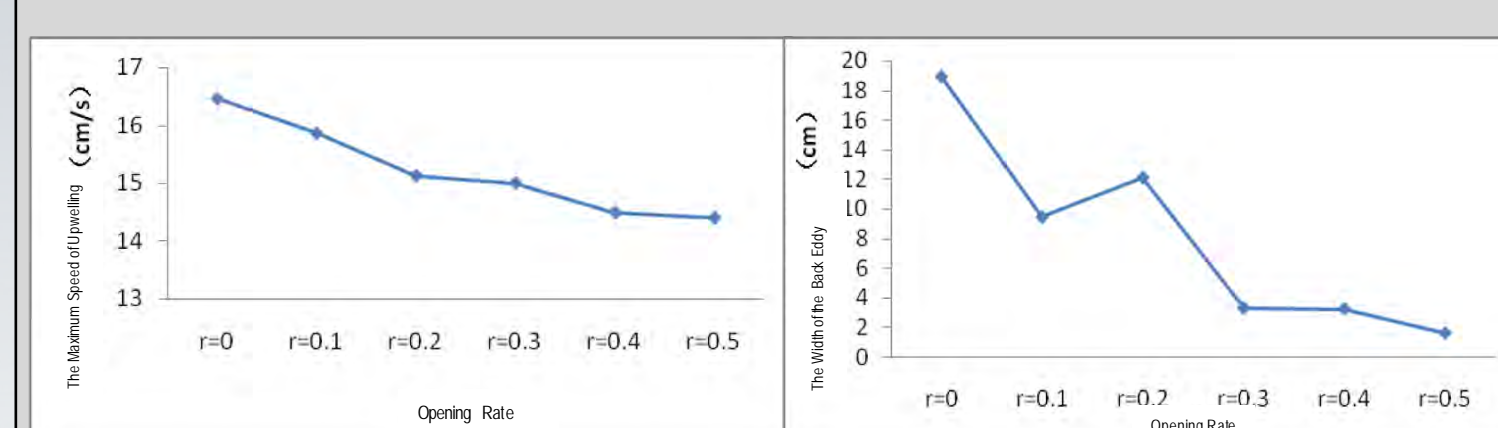

Figure 6: Upwelling maximum speed changing along with the opening ratio

The study mainly focus on the changing trend of the Upwelling speed in the front part of reefs and the width of Back eddy current along with the opening ratio. The Upwelling maximum speed turns to be the maximum speed among the Vertical direction in the area. There appears two vortexes right behind the reef body while the reefs are open. And fish are more likely to gather in the low part of vortexes, which explains the value of Back eddy current to be the level of the largest span of the back of reefs in this study.

2. The Manners of Yellow Fin Tuna [1994-2012]

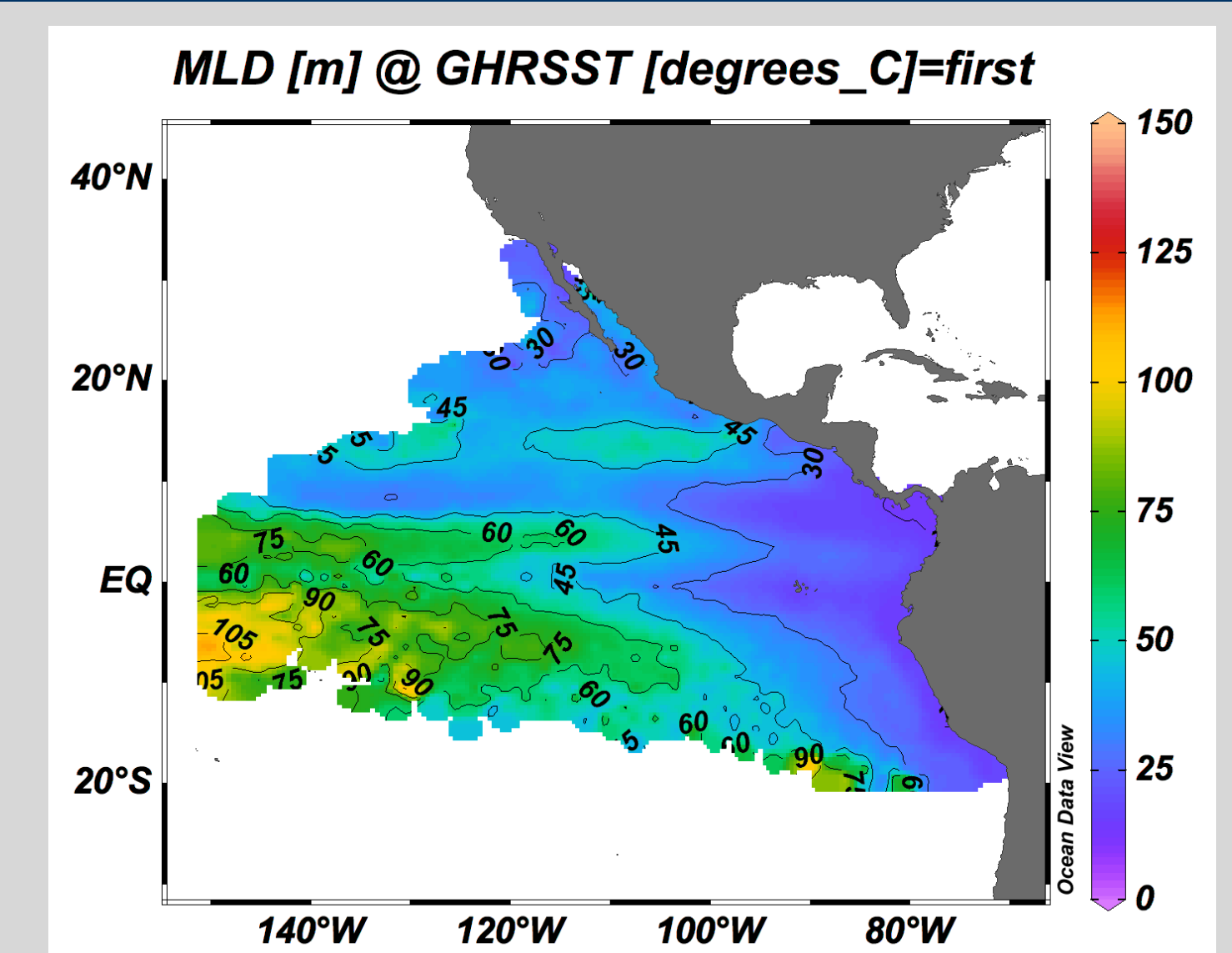

Figure 7: The average MLD of east pacific ocean [1994-2012]

First things first, we analyzed this area's MLD, and we can find the equatorial current and equatorial counter current signs from the contour line. The cold water mass from the seafloor of offshore of South America bring a many of nutrient and reform the shape of MLD. The yellow fin tuna choice to prey rather than stay in warmer water. While the MLD where is remarkable deeper is lack of tuna's activities.

Signals of Interannual Variations

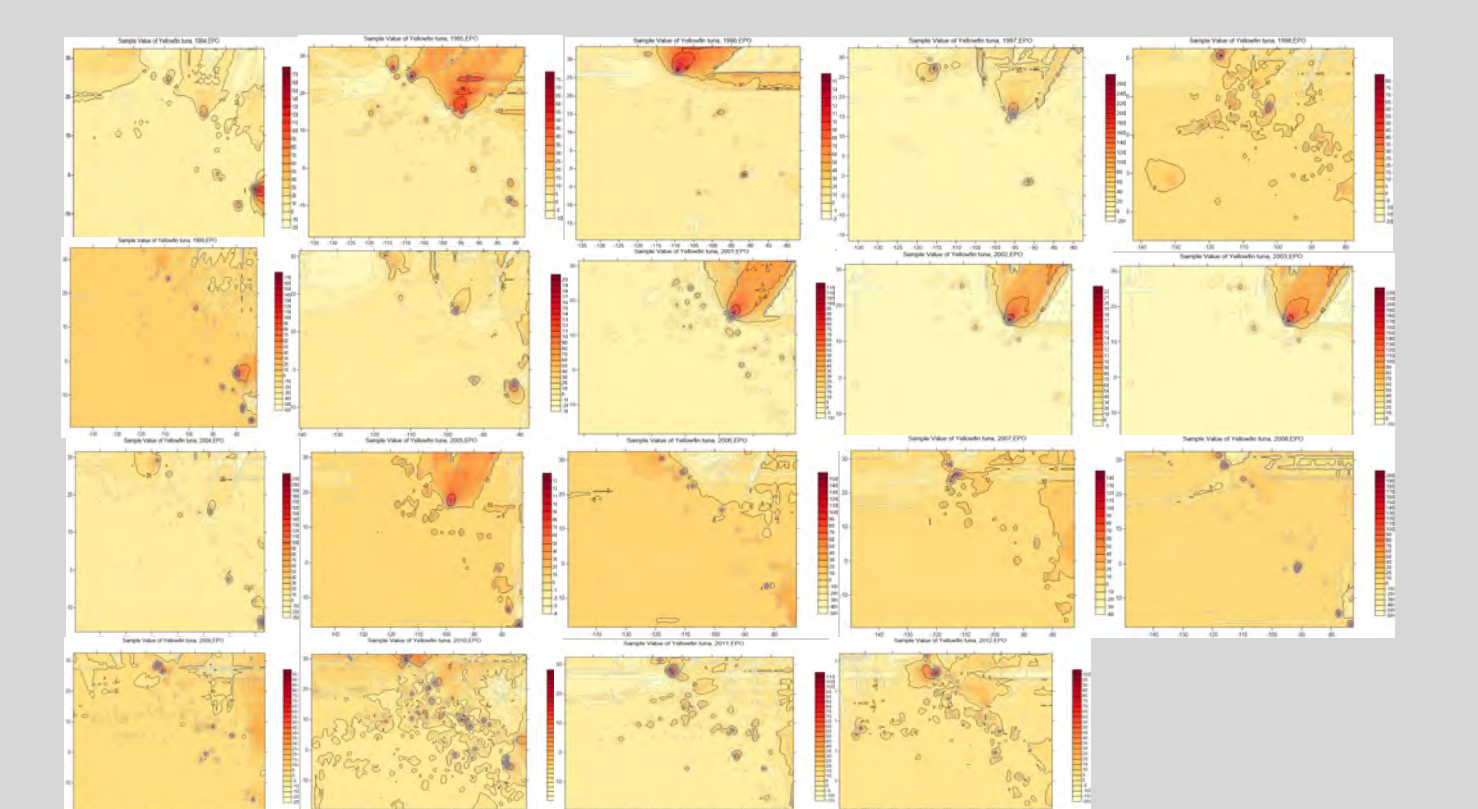

Figure 8: The variation of sample value (fishing) of yellow fin tuna [1994-2012]

Since 1994, there is a repeated change mode of Tuna distributions, and also a convergence and divergence between annual sample value. The counterbalance movement's regulations maybe relate with ENSO event. In terms of signals patterns, in some years , it appeared a distinct peak.

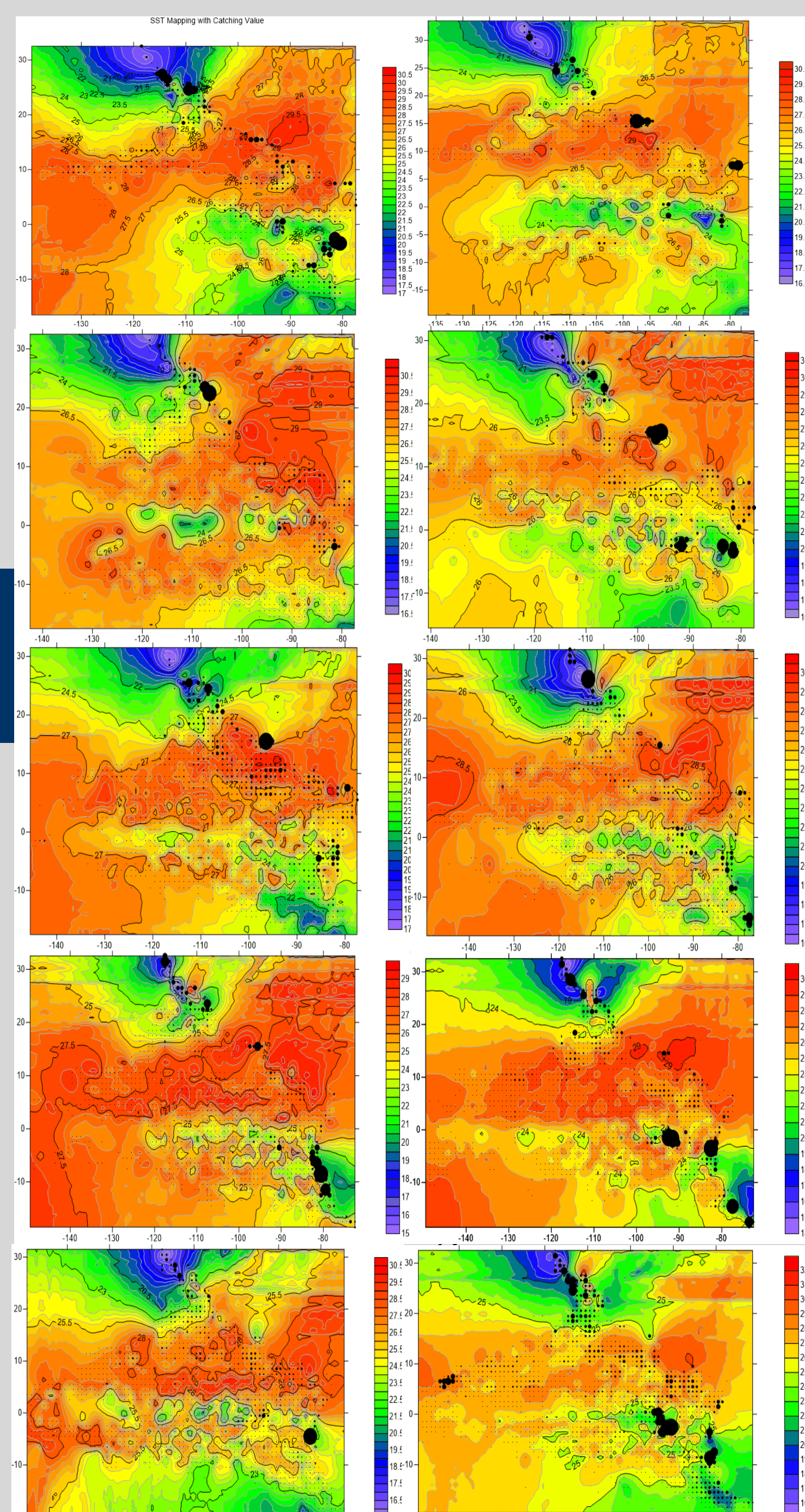

Figure 9: The SST mapping with CPUE data

Analysis of Fishery Resource Shift

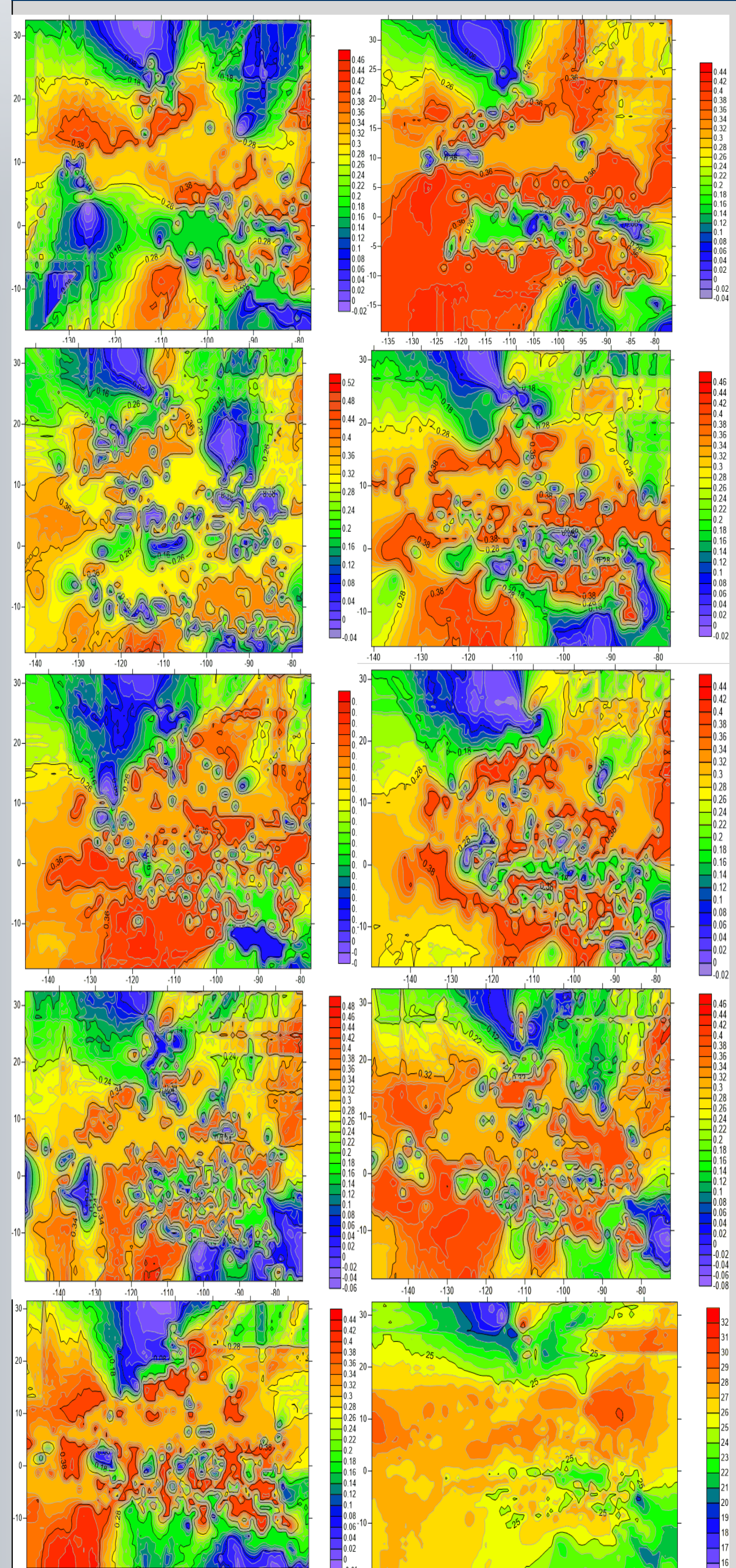

Figure 10: The Variation of tuna density

The CPUE data of this area displays that the yellow fin tuna have two main assemble location in this area, and both of them were have a movement to the north. Although they are tropical species, they preferred to relatively cold water in this area.

The Equatorial Counter Current can be obvious found which strengthened by ENSO and prevailing wind and influenced the distribution of tuna (by biological or environmental factors). And the density of tuna also have shift-down signals and fragmentation phenomenon.

As it is indicated in the picture, the negative signal gradually trend to miniaturization while the flux of positive signals enlarging. This matter have an greatly correlations with SST variation trend. The spatial and temporal distribution give us insight into a new scenario.

3. Conclusions

- For first study Through the process of the opening increasing from 0 to 0.6 , the Upwelling maximum speed decreases. When r =0.2, there is an optimization effect both back eddy and upwelling.
- For second study, we find there is a periodical change during those years, and tuna may migrate northerly in every five years period which may associate with ENSO events. And there also are strongly signals for global warming and fishery resource degradation.
- The peaks of individual value of yellow fin tuna appeared and dis appeared back and forth, and there is northward tendency of both SST and population density.